

The Electric Power System

- Japan -





Basic figures

- ❑ Area: 377,962km² (source:MIC)
- ❑ Population: 126.5million(2018/5) (source:MIC)
- ❑ Number of electricity consumers: approx. 85million
(FY2016, source:FEPC)
- ❑ Number of T&DSOs: 10
(TSO and DSO are integrated per electric power company)
- ❑ Peak load: 156GW(FY2016) (source:FEPC)
- ❑ Average interruption of electricity: 25min(FY2016)
(per customer The influences due to natural disaster such as typhoon are included. source:FEPC)

MIC: Ministry of Internal affairs and Communications
FEPC: The Federation of Electric Power Companies of Japan



Global interconnections

- No interconnection to any other countries (Island country)





Grid facts

- The electricity grid in Japan is sub-divided into transmission grids(basically higher than medium voltage) and distribution grids(basically 6.6kV and lower).

	Voltage Level	Total Length(approx.)	Responsibility
Transmission Grid	500kV	7,900km	TSO
Transmission Grid	187kV,220kV,275kV	13,500km	TSO
High Voltage	66kV to 154kV	62,000km	TSO
Medium Voltage	6.6kV to 66kV	19,500km	TSO (Partially DSO)
Medium Voltage	6.6kV	740,000km	DSO
Low Voltage	100 or 200V	576,000km	DSO

(source:FY2016,FEPC)





Structure of power system

Trunk(EHV) system: Loop, Sub-transmission(HV,MV): Radial

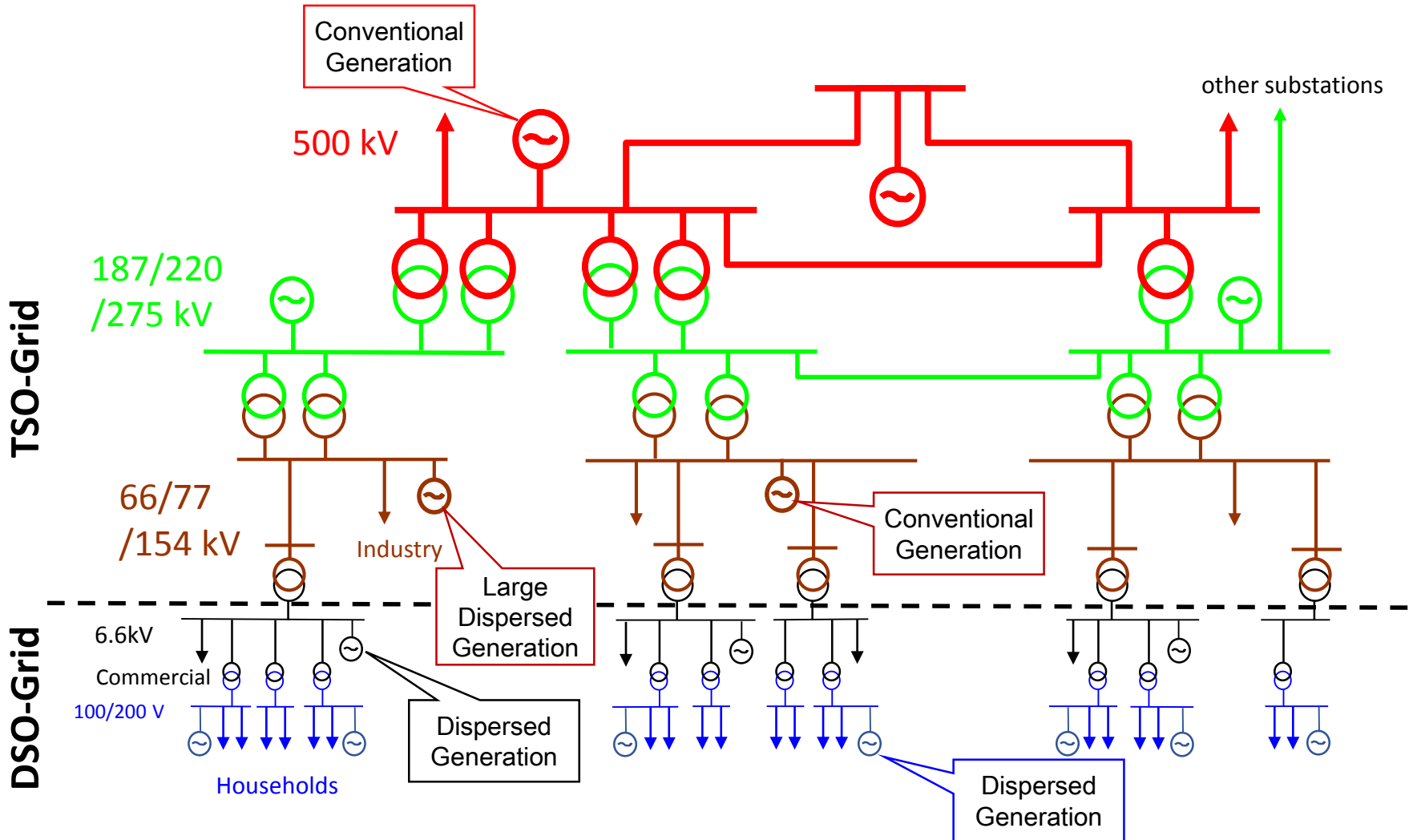



The extra high voltage grid

Two Frequencies

- 50Hz at Eastern
- 60Hz at Western
- DC linked interconnections by Frequency Converter

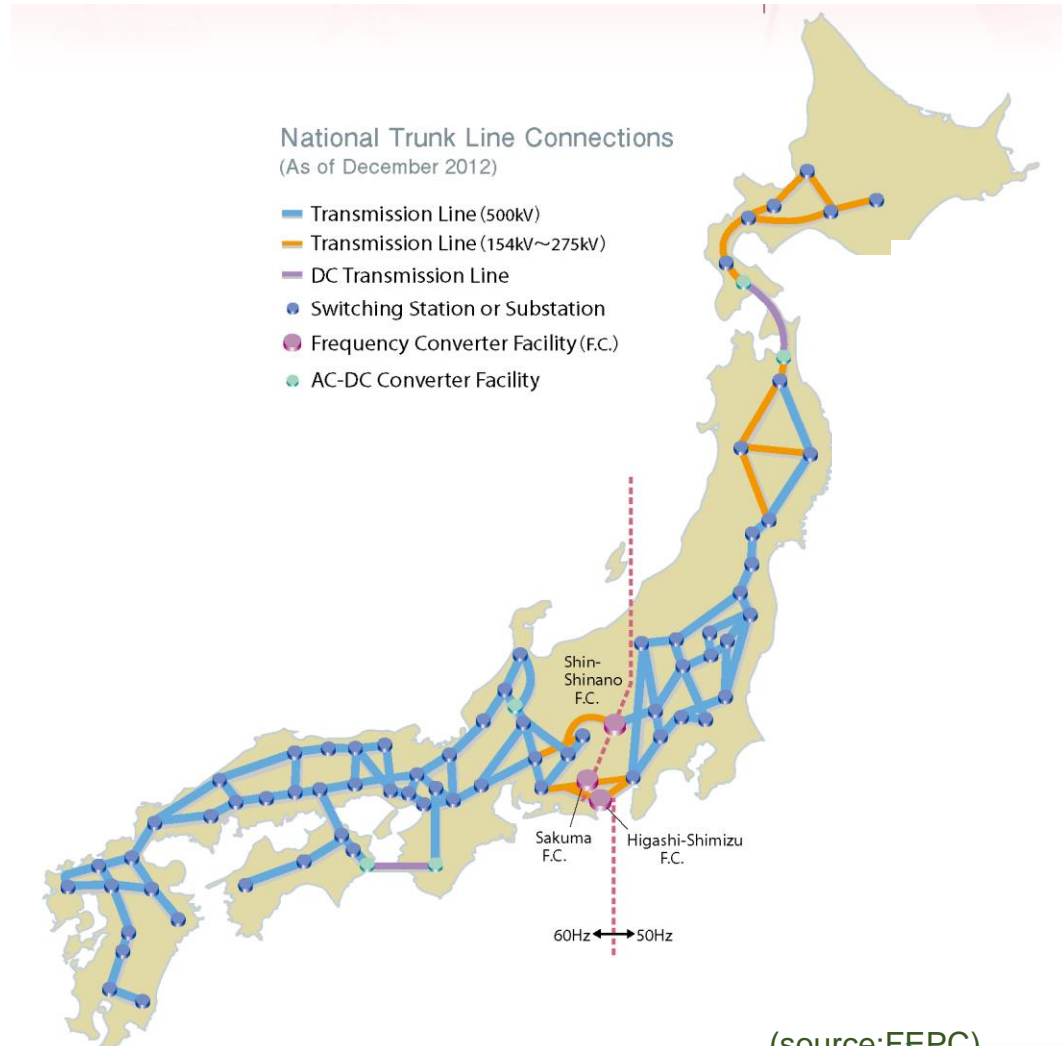



Map on 10 Japanese T&DSOs

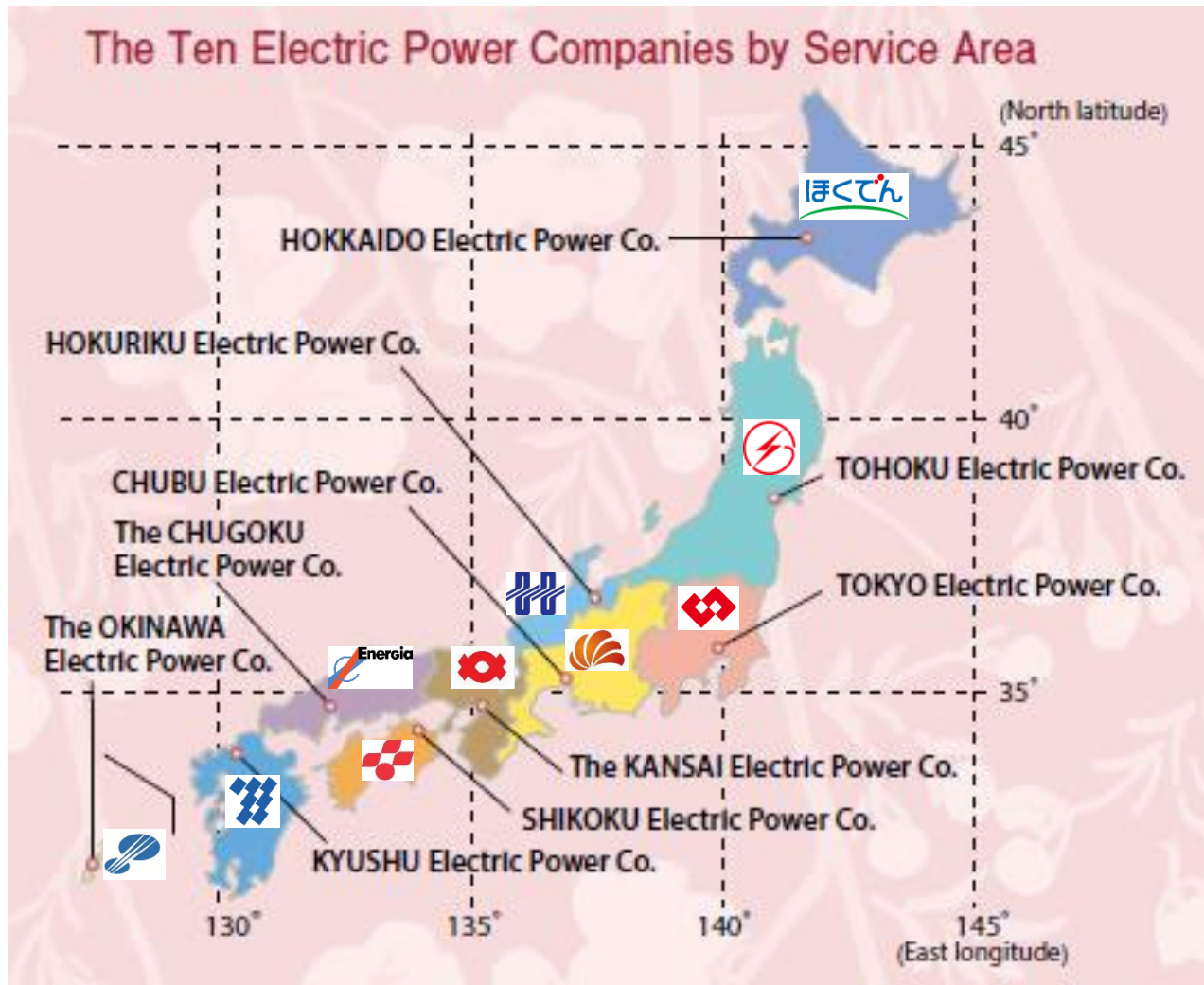

(source:FEPC)





Ten Japanese T&DSOs

T&DSOs	Network Length ^{*1} [km](500kV)	Network Length ^{*1} [km] (187-275kV)	Served area [km ²]	Generating Capacity [MW]	Annual Area Electricity Sales ^{*2} [TWh]	Shared load[%]
Hokkaido	0	2,450	78,400	7,957	28.6	4
Tohoku	552	2,173	79,500	17,956	75.1	9
Tokyo	2,493	1,573	39,500	66,802	247.1	31
Chubu	890	1,512	40,300	33,168	122.0	15
Hokuriku	234	241	12,600	8,074	27.5	4
Kansai	1,682	1,854	27,300	36,573	127.5	16
Chugoku	828	1,012	31,900	11,536	56.7	7
Shikoku	279	982	18,800	6,617	25.8	3
Kyushu	942	1,733	42,200	18,701	79.2	10
Okinawa	0	0	2,300	2,155	7.6	1

(source:FEPC,*1:FY2015,*2:FY2016)





T&DSO's Web site

TSOs	Web site URL
Hokkaido	http://www.hepco.co.jp/english/index.html
Tohoku	http://www.tohoku-epco.co.jp/english/index.html
Tokyo	http://www.tepco.co.jp/en/index-e.html
Chubu	http://www.chuden.co.jp/english/index.html
Hokuriku	http://www.rikuden.co.jp/english/index.html
Kansai	http://www.kepco.co.jp/english/
Chugoku	http://www.energia.co.jp/e/index.html
Shikoku	http://www.yonden.co.jp/english/index.html
Kyushu	http://www.kyuden.co.jp/en_index.html
Okinawa	http://www.okiden.co.jp/english/index.html





Organization for Cross-regional Coordination of Transmission Operators (OCCTO)



Functions required for Wide Area System Coordination

- Assessment of the adequacy of electricity supply-demand
- Proper utilization of transmission capacities
- Authorization for new construction of transmission facilities
- Management of tie-line power flow, etc

OCCTO Website URL <https://www.occto.or.jp/en/index.html>



Installed capacity by primary resources

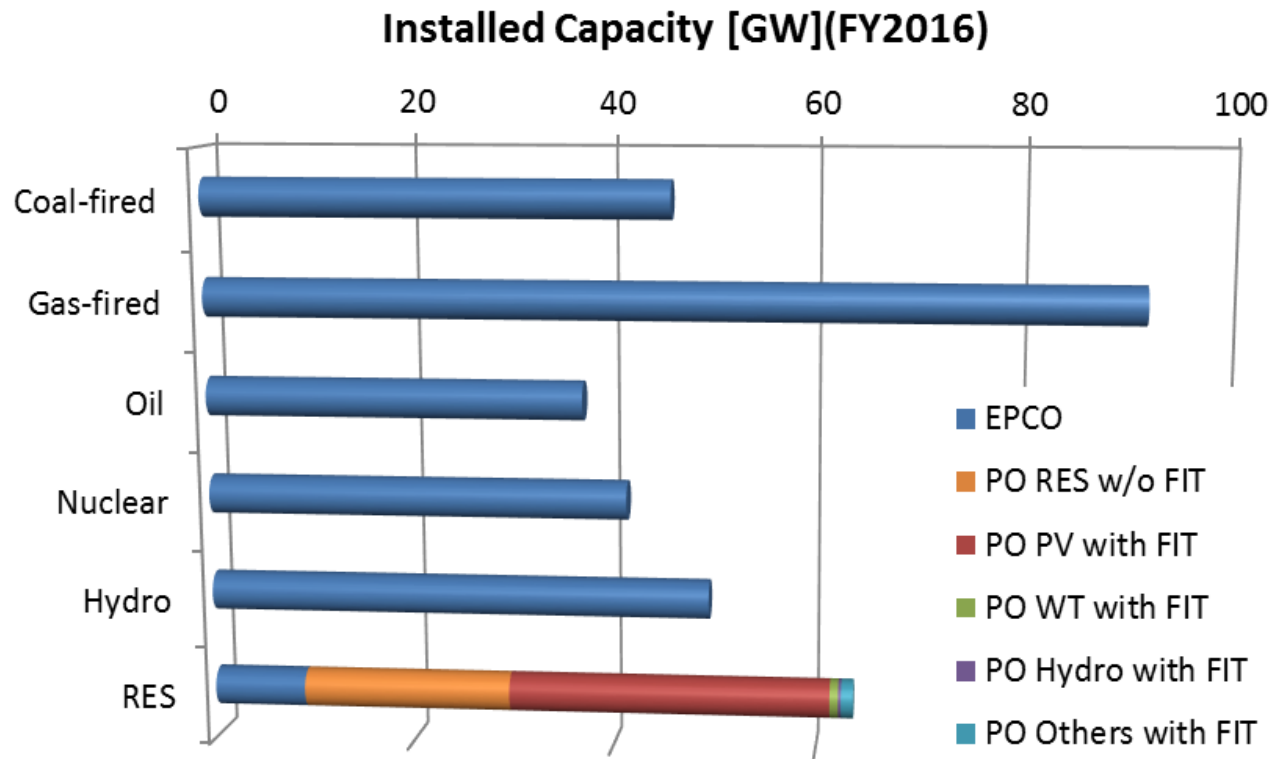

EPCO: Electric Power Company's Own

PO: Private Own

FIT: Feed In Tariff

(source: FEPC, METI in FY2016)



Energy production by primary resources

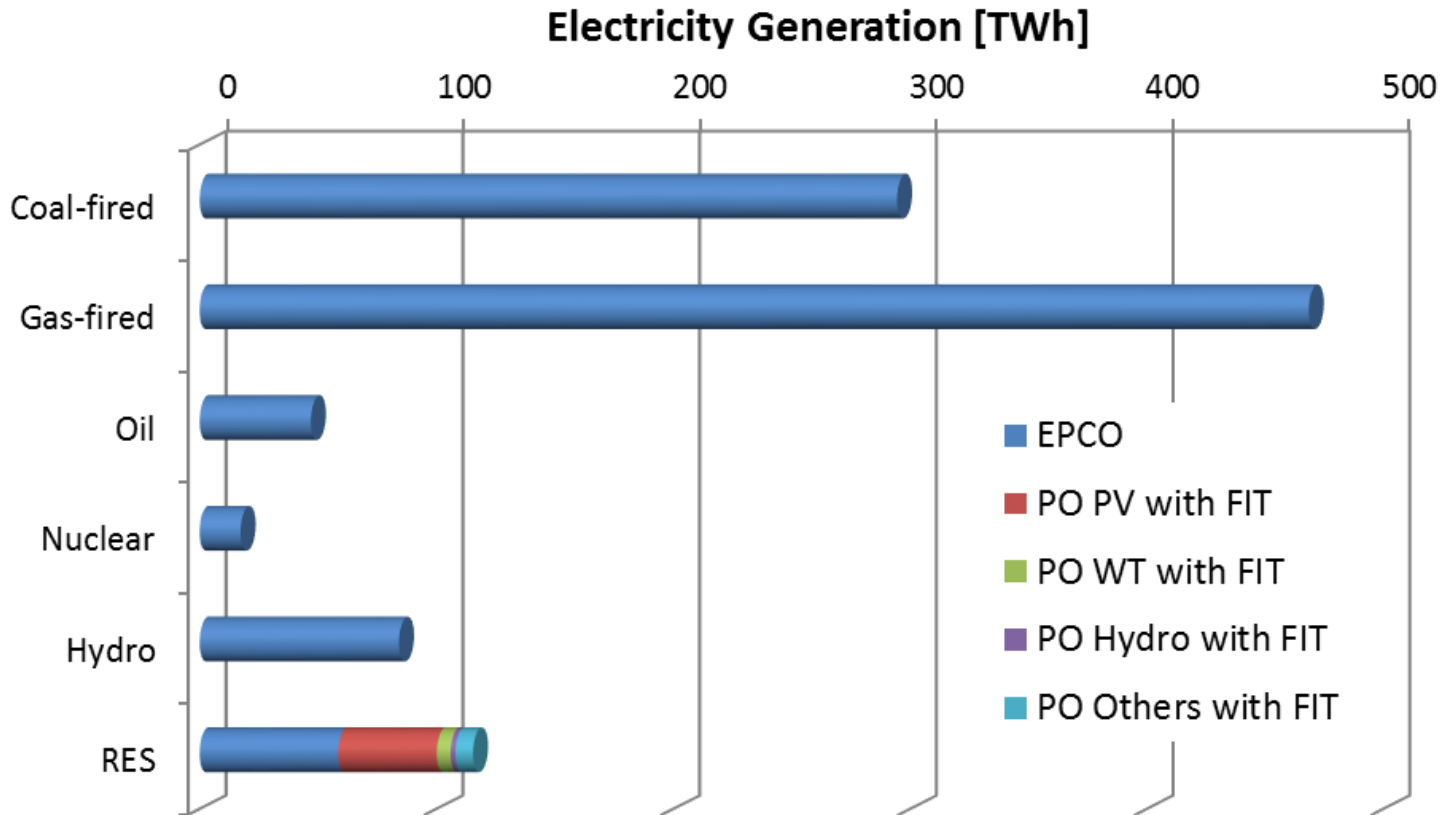

EPCO: Electric Power Company's Own

PO: Private Own

FIT: Feed In Tariff

(source:FEPC,METI in FY2016)





Development of generation capacity since 2010

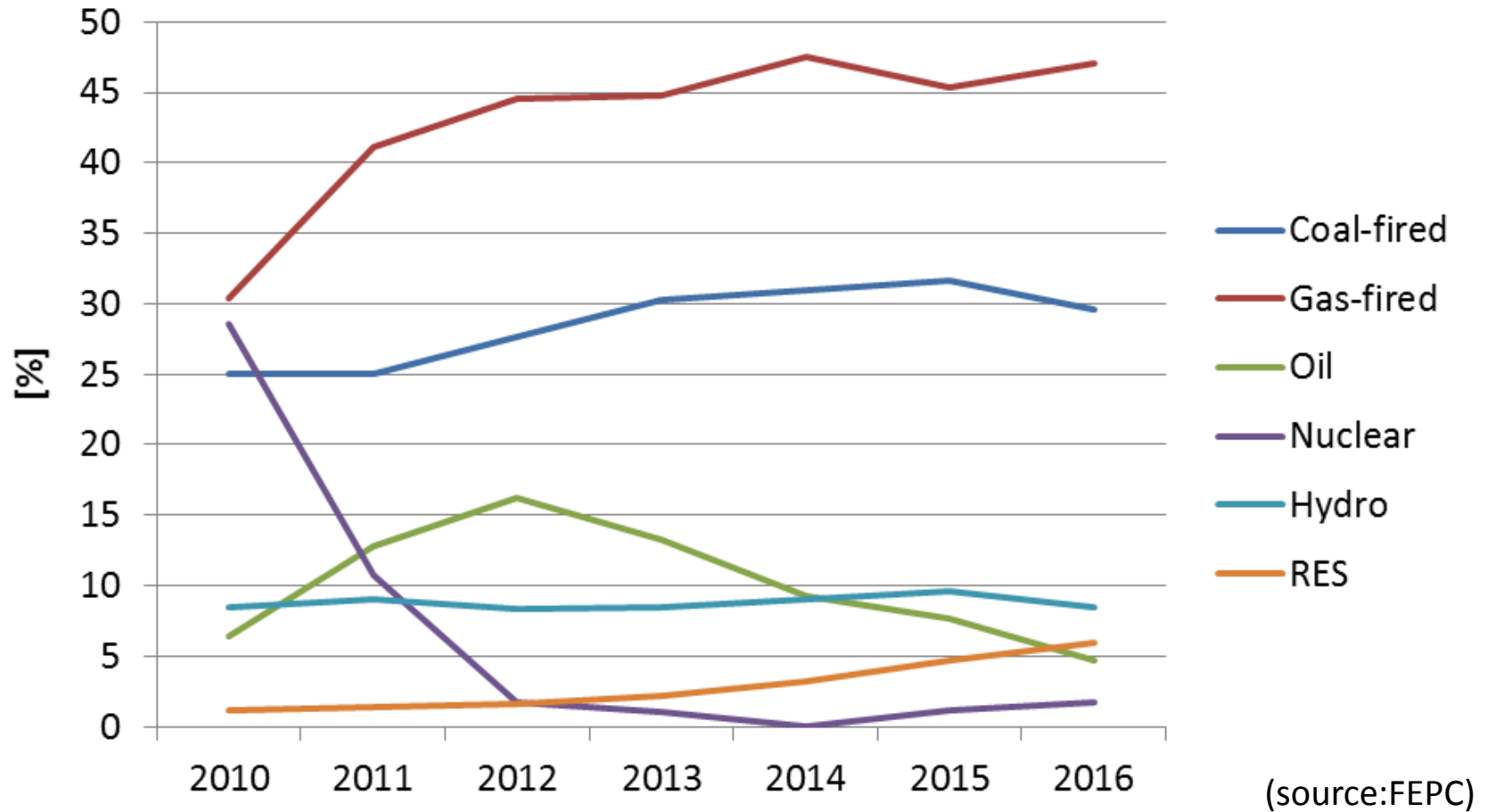



Consumption per customer groups (FY2016)

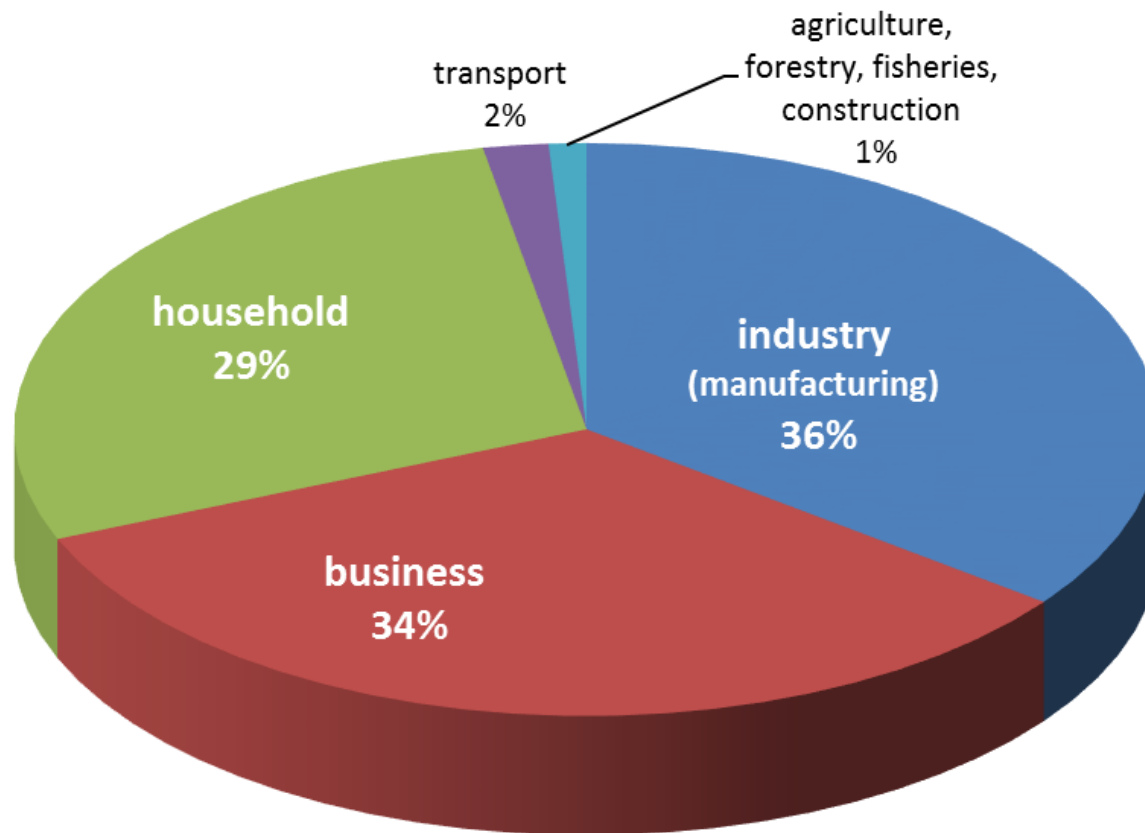

(source: Agency for Natural Resource and Energy, Japan)





Price development for industry consumers and households

- Average price is based on the total income of utilities from each type of customers divided by respective electricity sales annually.

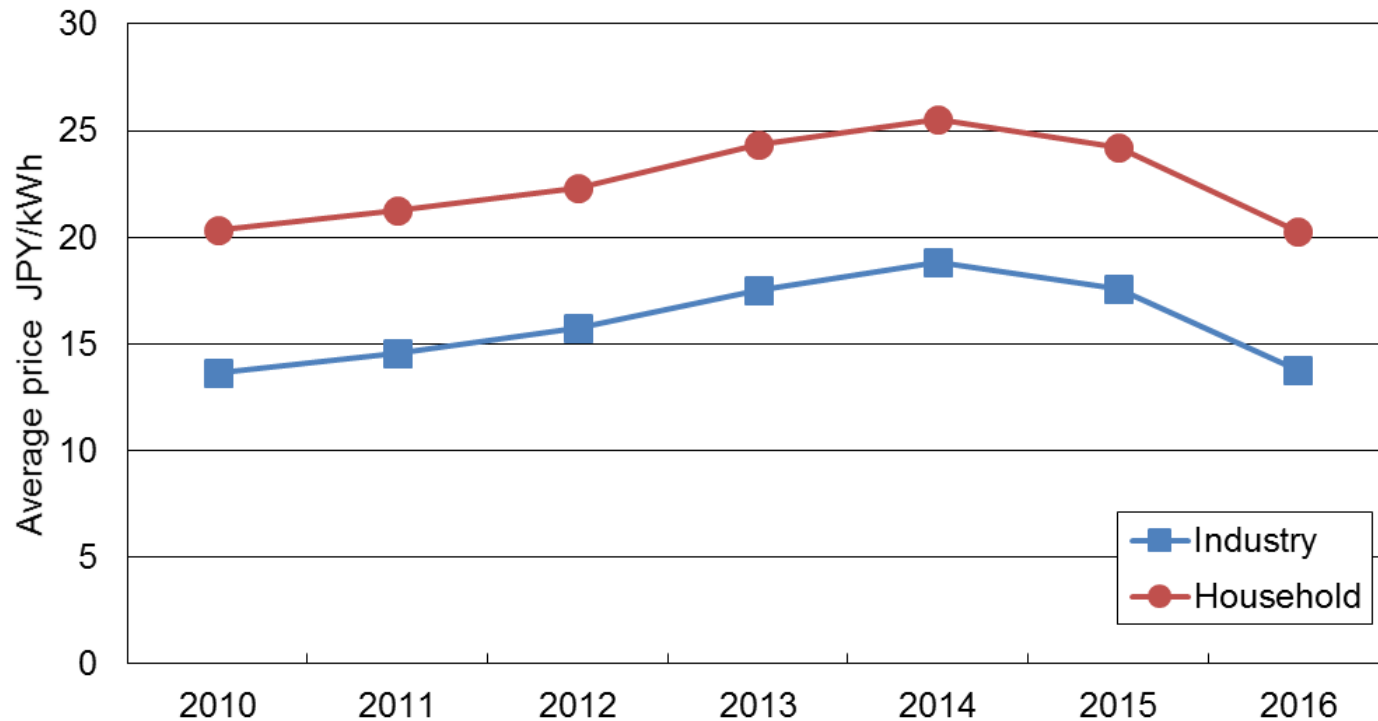

(source: Agency for Natural Resource and Energy, Japan)



Installation of smart meters

- Amounted to 23.2 million units as of Nov. 2016

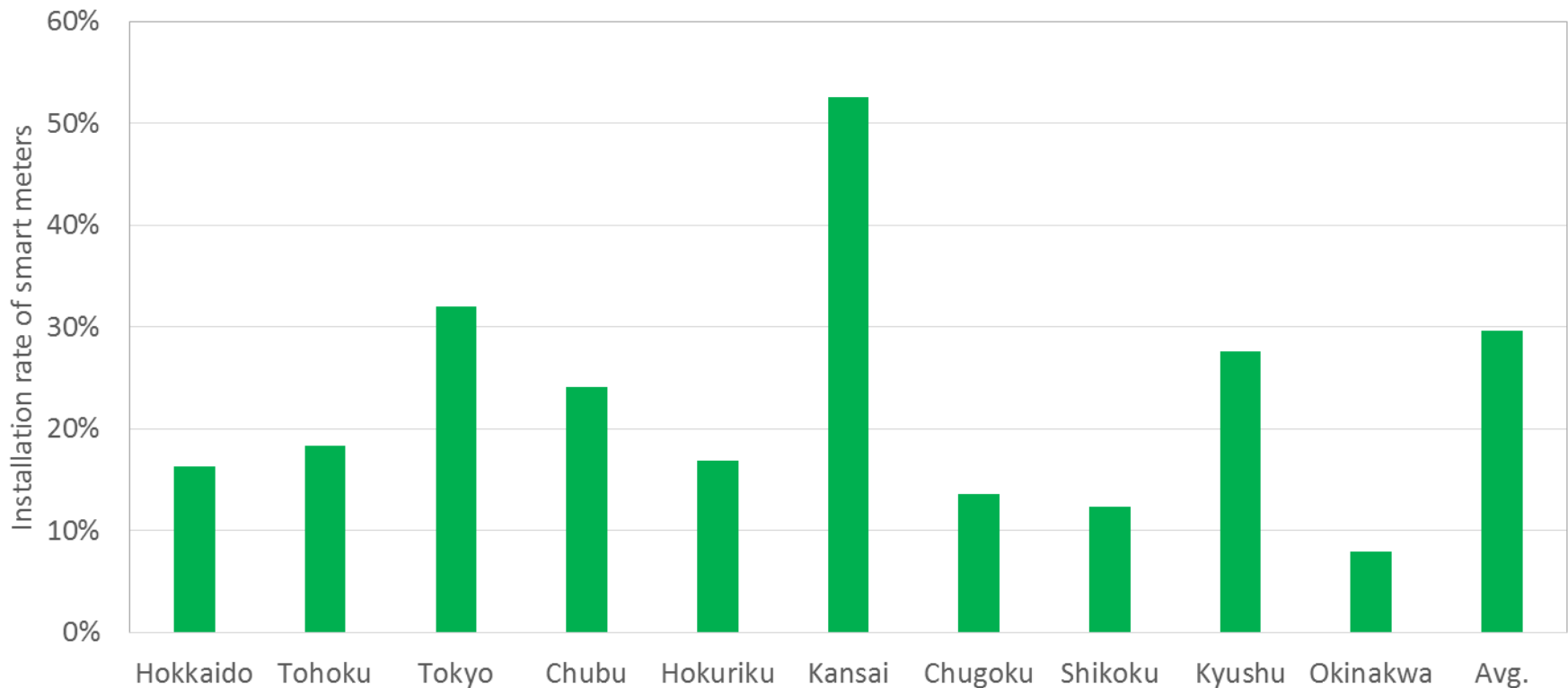

(Source: Electricity & Gas Market Surveillance Commission)





Renewables





Location of RES

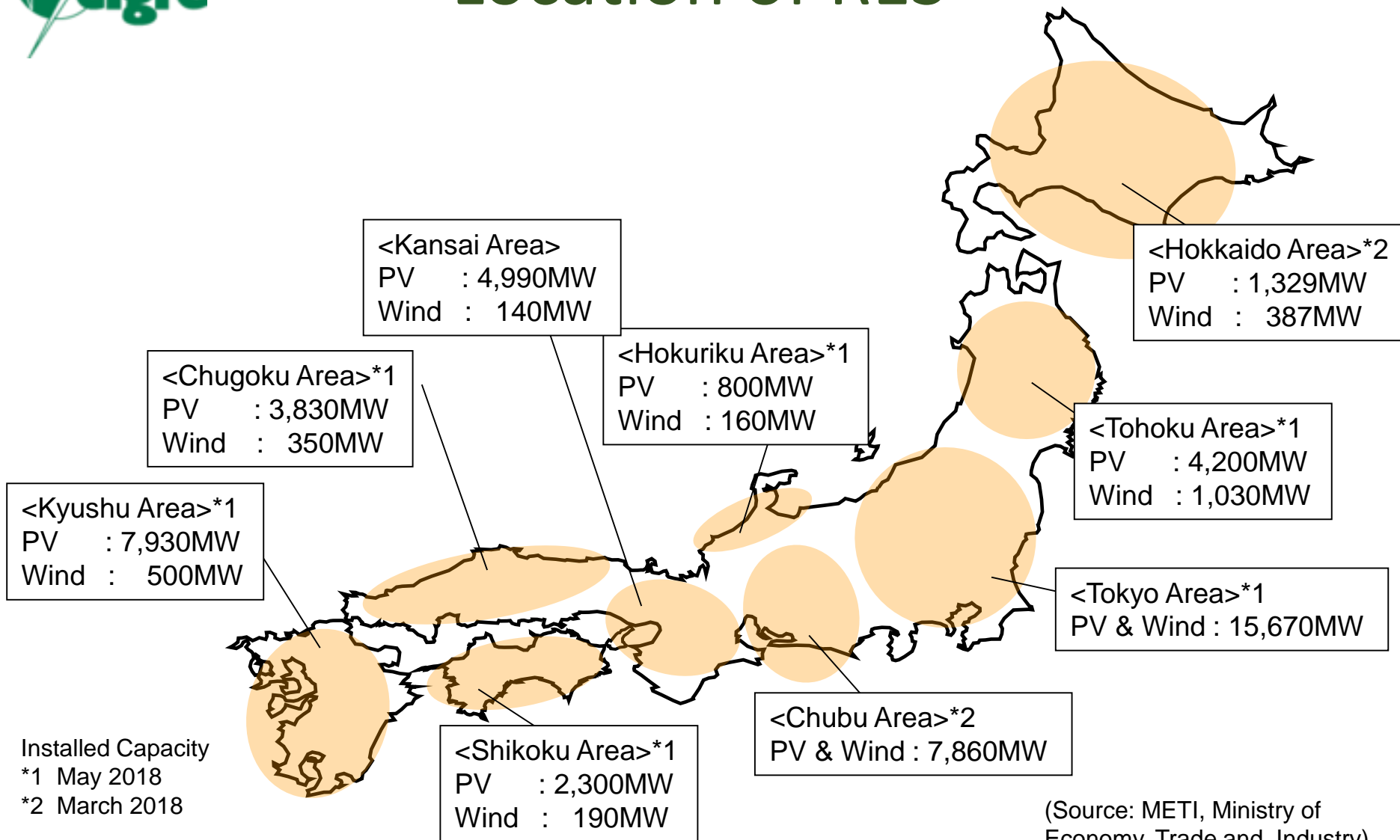

Installed Capacity

*1 May 2018

*2 March 2018

(Source: METI, Ministry of Economy, Trade and Industry)





Development of wind power

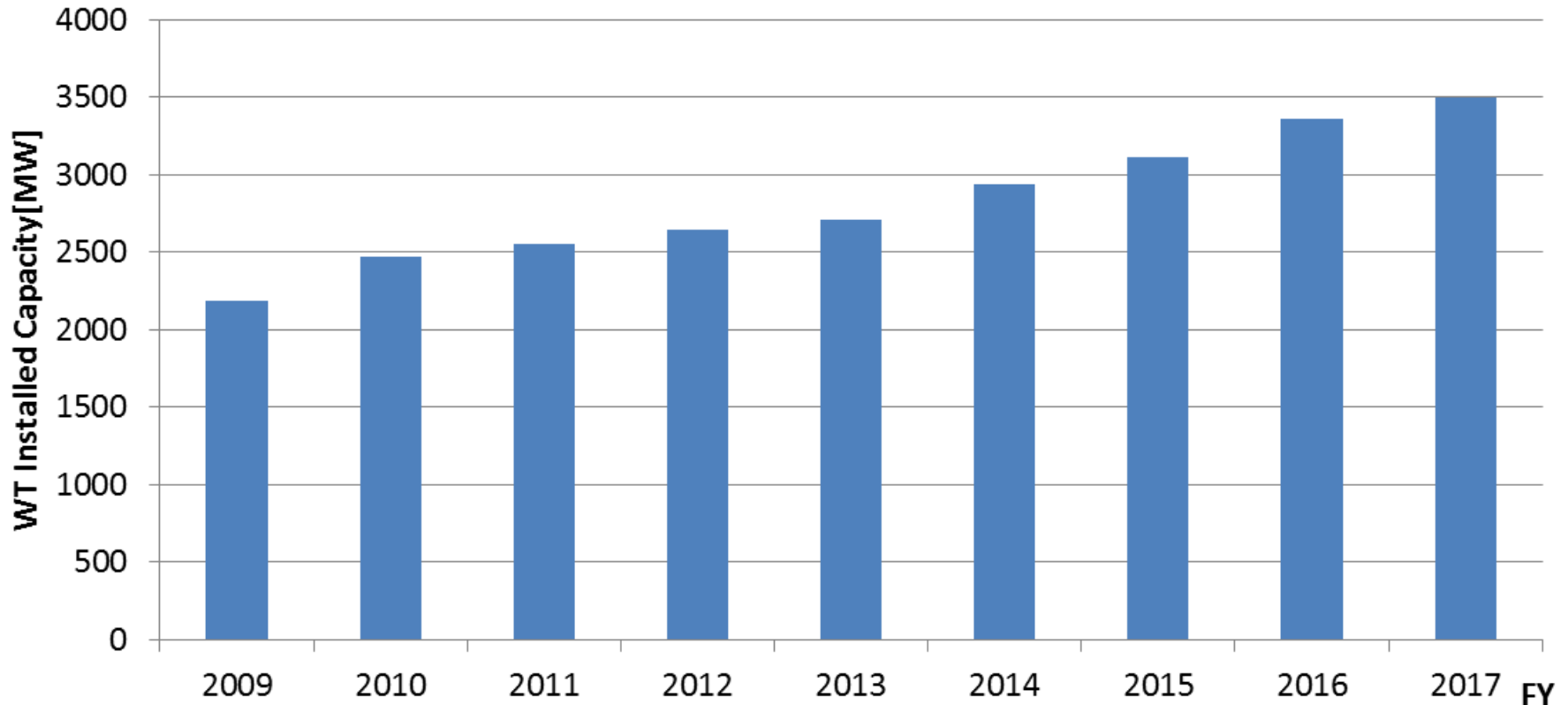

(Source: FEPC)





Development of PV power

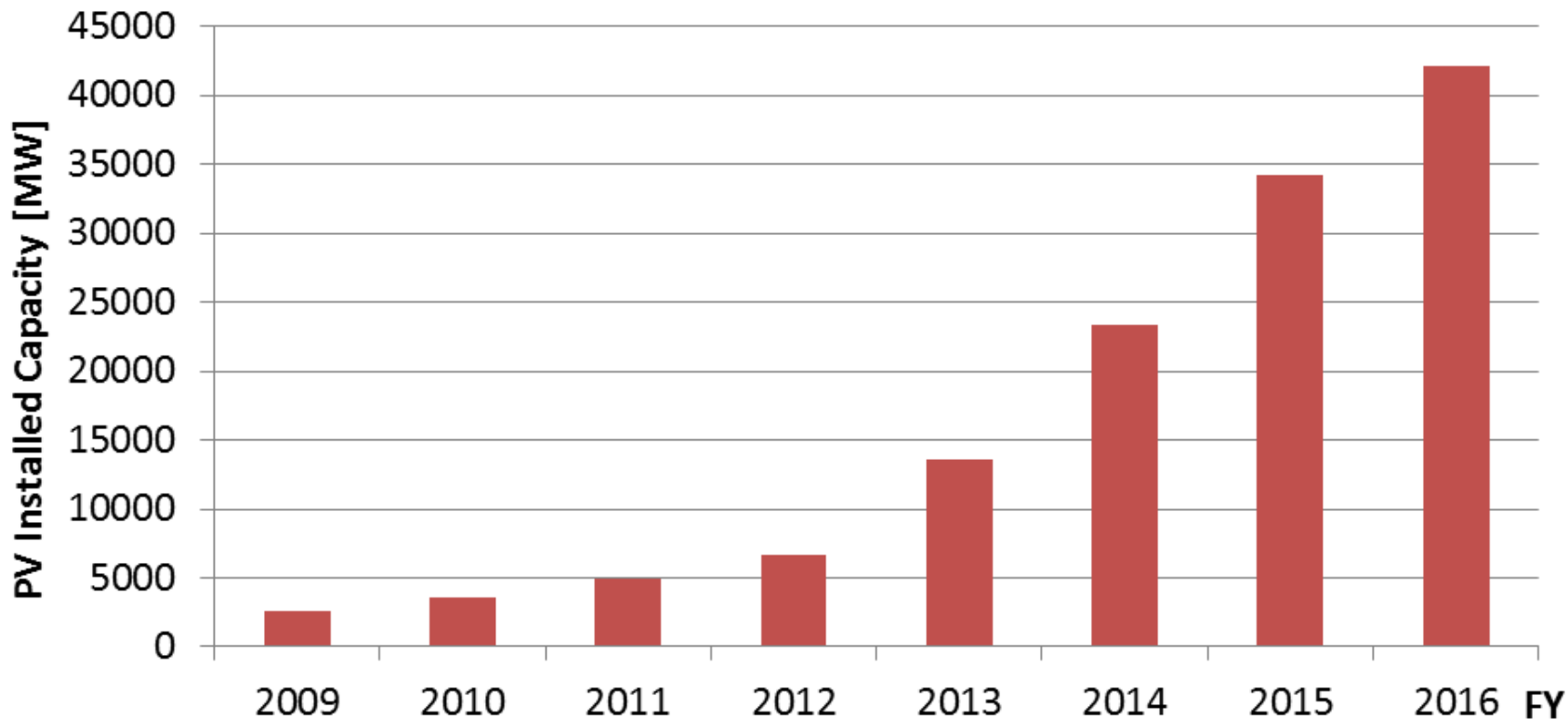

(Source: FEPC)



Market





Reform program based on step by step schedule

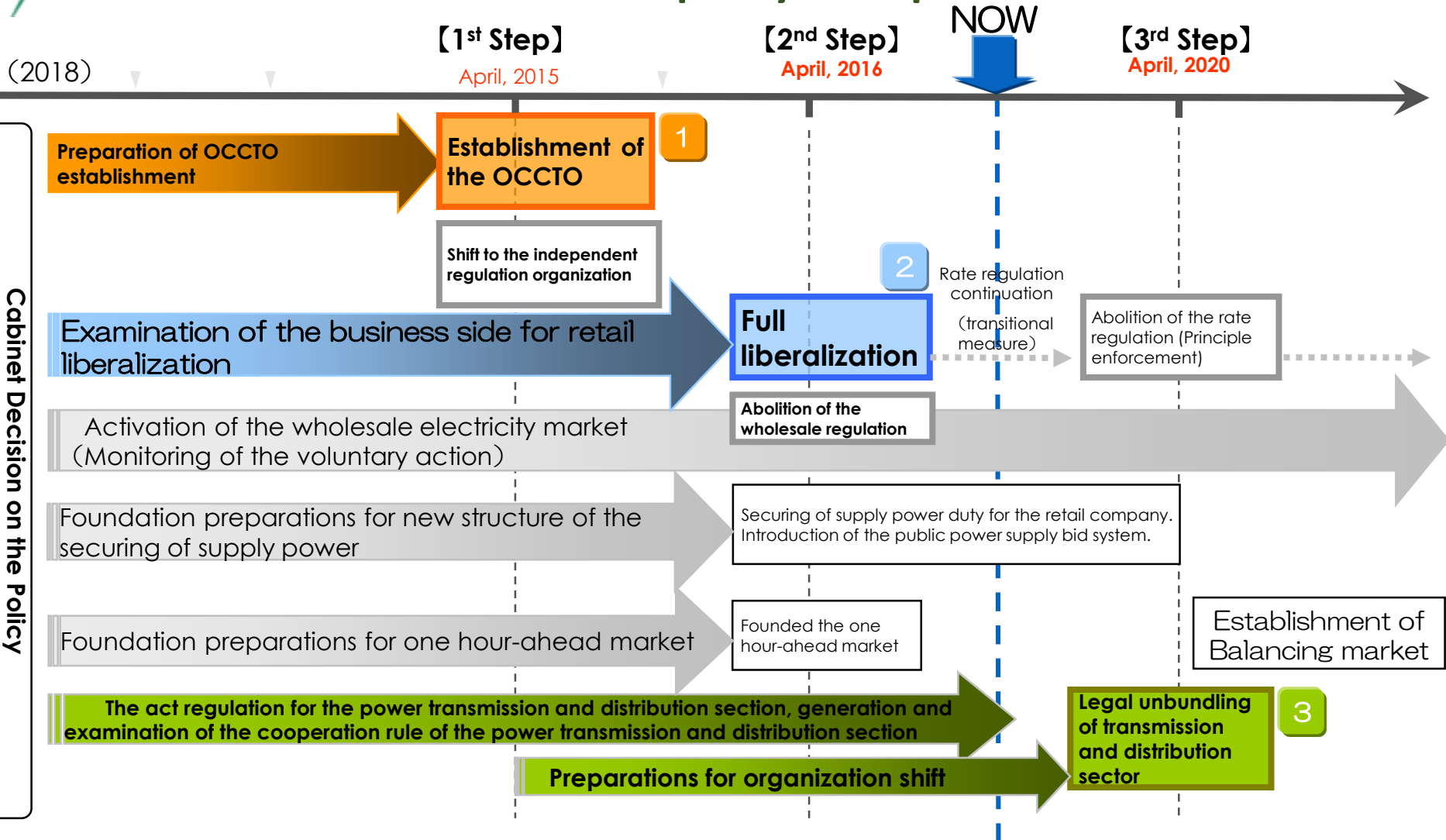



Present electricity market structure

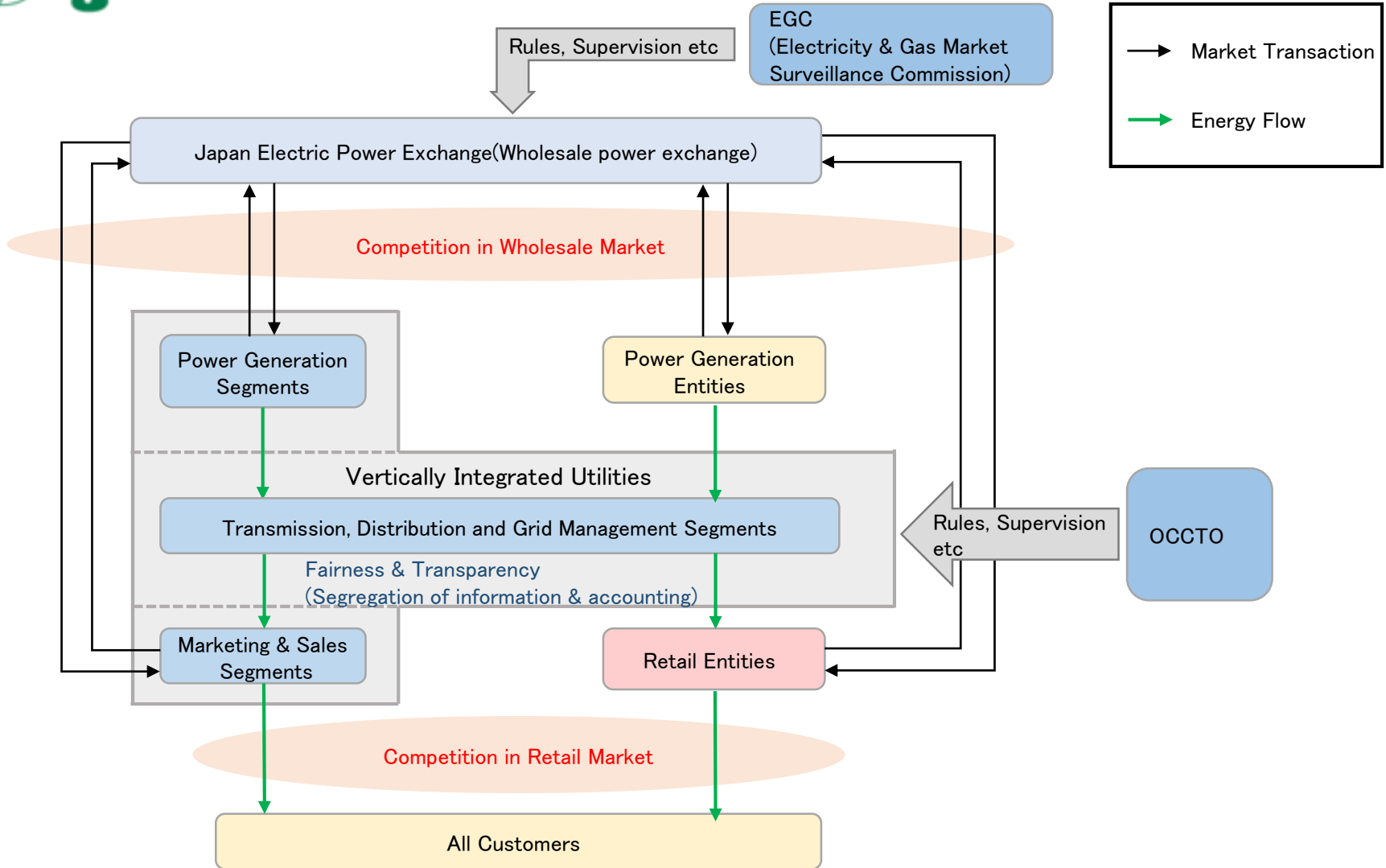

<Source: FEPC(partly modified)>



Power exchanges

Peak Demand of Each Supply Area in summer of FY 2016

Physical Power Flow of Interconnection in Average in FY2016

(source OCCTO)

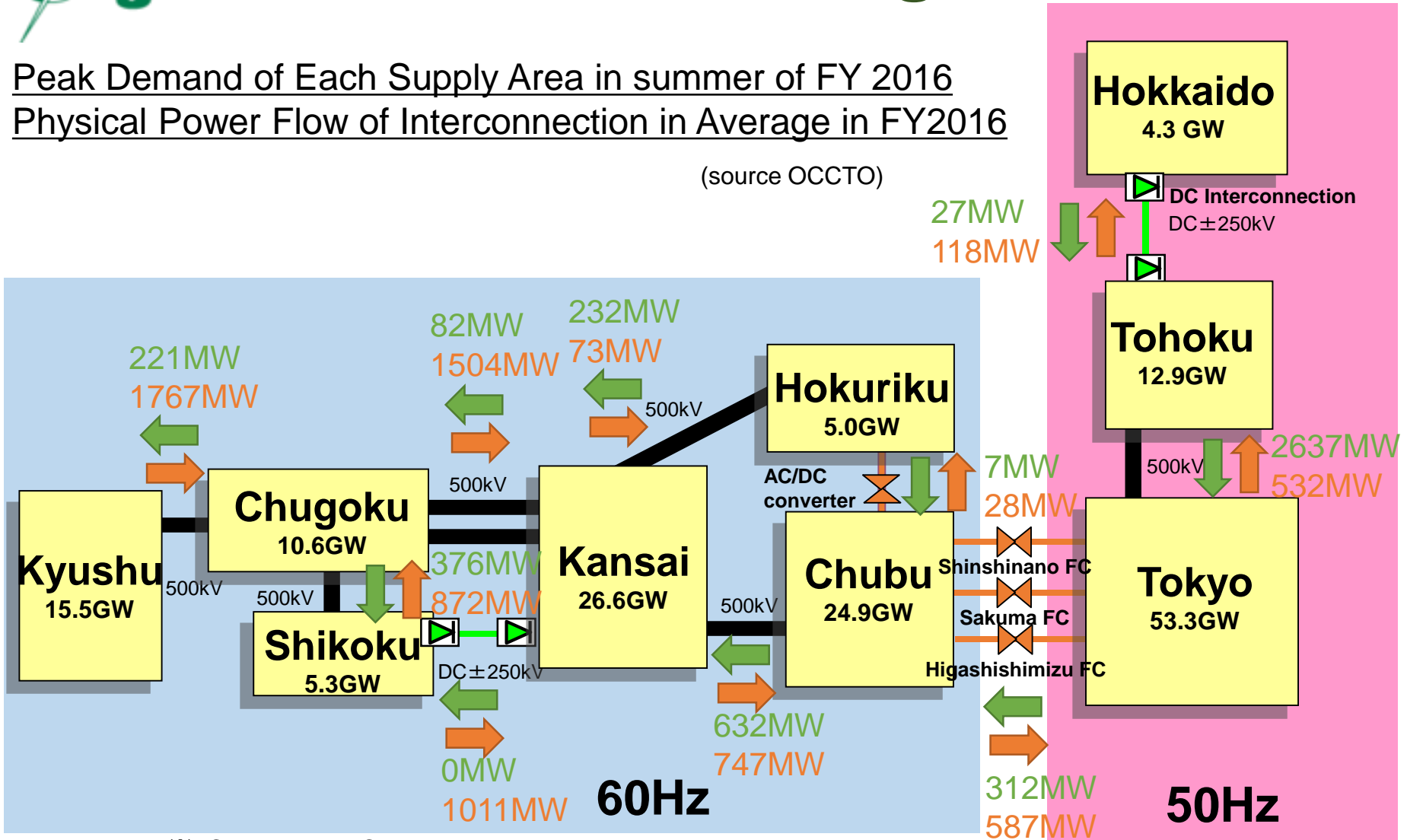

※FC: Frequency Converter



Specific aspects of the present electricity market

□ Market type & Features

➤ Day-ahead market

- ❖ Single price auction system
- ❖ Transaction time is 10:00 a day before
- ❖ Market split when transaction exceeds interconnection capacity

➤ One hour-ahead market

- ❖ Continuous session system
- ❖ Transaction begins at 17:00 a day before

➤ Forward market

- ❖ Continuous session system
- ❖ Monthly products, weekly products
- ❖ 24-hour type, daily hour type